

# XTRU-4803

Commercial Series | LED STEP LIGHTING

**IMPACT**  
LIGHTING



Impact Lighting's XTRU-4803 Commercial Grade Series Step Lighting is an aluminum stair housing profile with LED tread and riser illumination. Perfect for high traffic commercial applications such as lighting in theaters, shops, nightclubs and restaurants, this profile offers superb durability and style.

**ADA Complaint\***

*\*Pending installation, product designed to conform to the needs of people with disabilities*

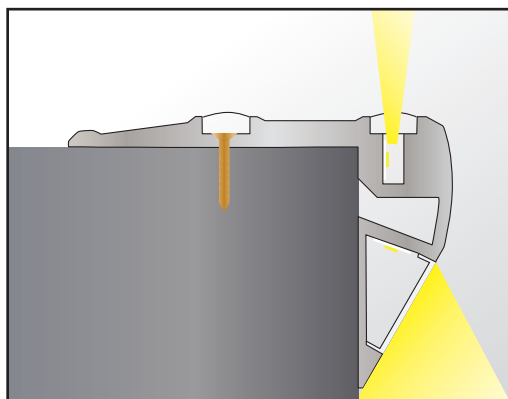

#### KEY FEATURES:

- Resistant to high intensity pedestrian traffic
- Fixed to the finished edge of a step with screws or an adhesive
- Can be installed on carpeted steps
- Anti-Slip Surface
- End caps
- No visible LED points
- Custom cut to length (max 2 meters / 78 inches)

**Impact Lighting Inc.**

3100 Pennington Road, Orlando, Florida 32805 USA • Phone: 1.800.507.5714 • Email: [sales@impact-lighting.com](mailto:sales@impact-lighting.com)

[www.impact-lighting.com](http://www.impact-lighting.com)

PROJECT	DATE
TYPE	QTY.

**ADA COMPLIANT STEP LIGHTING w/ TREAD & RISER ILLUMINATION**

Impact Lighting's **XTRU-4803 Commercial Series** Step Lighting is an aluminum stair housing profile with LED tread and riser illumination. Perfect for high traffic applications such as lighting in cinemas, shops, nightclubs and restaurants, this profile offers superb durability and style. ADA Compliant\* for persons with disabilities.

*\*Pending installation, product designed to conform to the needs of people with disabilities*

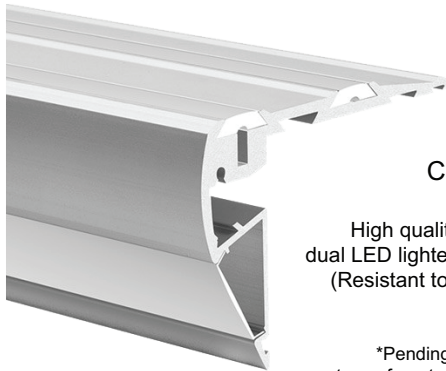

**XTRU-4803**  
Commercial Series

High quality double-anodized aluminum dual LED lighted stair profile with anti slip surface. (Resistant to high intensity pedestrian traffic)

**ADA Compliant\***

*\*Pending installation, product designed to conform to the needs of people with disabilities*

**KEY FEATURES**

- Fixed to the finished edge of a step with screws (not included)
- Can be installed on carpeted steps
- Anti-Slip Surface
- Custom cut to Length (max 2m / 78.75in)
- Tread light and Riser light options
- Minimizes the risk of tripping
- Three lighting variants
- High mechanical resistance
- ADA Compliant\*
- Sold with two Anti-slip rubber strips
- Mounts flush to the vertical plane of the step. Fits 30 degree angle
- Bottom LED strip directs light forward
- LED strip width (up to 6 mm) emit light from the side in channel under the silicone strip
- Standard LED strip width (up to 10 mm) to illuminate the step

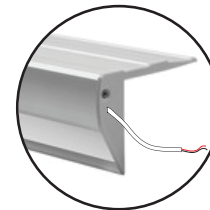
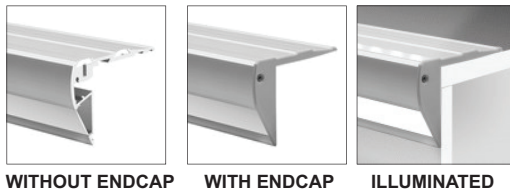
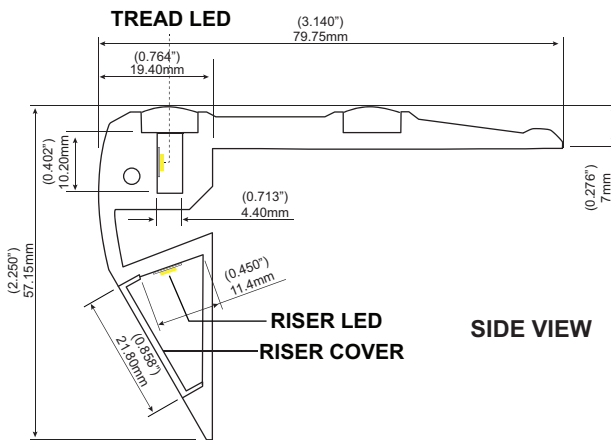

Lead wire location can be specified as right or left facing (Right Facing Shown)

**ORDERING** | **Example:**  
**XTRU-4803 - 24" - WW - CW - FR - R - 12 - L**  
XTRU-4803 Profile, 24" Cut Length, Warm White Tread LED w/ Cool White Riser LED, Frosted Riser Cover, Right Facing Lead Wire, 12" Wire Length, Left Facing End Cap

MODEL	CUT LENGTH	TREAD LED	RISER LED	RISER COVER	LEAD WIRE LOCATION	LEAD WIRE LENGTH	END CAP
<b>XTRU-4803</b>	-	-	-	-	-	-	-
Aluminum Dual LED Lighted Stair Profile	Write desired length above (0.15m - 2.0m) (6" - 78.75")	<b>WW</b> - Warm White <b>CW</b> - Cool White <b>N</b> - None	<b>WW</b> - Warm White <b>CW</b> - Cool White <b>N</b> - None	<b>FR</b> - Frosted <b>CL</b> - Clear	<b>R</b> - Right Facing <b>L</b> - Left Facing <b>B</b> - Left & Right* (daisy chain)	Write Desired Length Above	<b>R</b> - Right Facing <b>L</b> - Left Facing <b>B</b> - Both Sides <b>N</b> - None

**Impact Lighting Inc.**